



4X4 EDITION: SUSPENSION CATALOGUE

10% OFF
ARMOR

+

FREE
HEAVY DUTY
AIR COMPRESSOR

**NEW YEAR.
NEW DEALS.**

10% OFF
CAMPING

+

FREE
LED LANTERN
OR TENT LIGHT

10% OFF
RECOVERY

25% OFF
LIFT KITS



INDEX

BUILD BIOLOGY	4
4RUNNER	5
TACOMA	8
PRODUCT	
IMS SHOCKS	11
MRR SHOCKS	11
COIL SPRINGS	12
REAR DRAWERS	13
CONTROL ARMS	14
SNORKELS	15
LIGHTS	15
ORS GUARANTEE	16



ORS246.com

BUILD BIOLOGY

WE USE OUR YEARS OF EXPERIENCE & INTERACTIONS WITH OUR CLIENTS TO DESIGN THESE PACKAGES - TAKING THE GUESS WORK OUT OF THE PROCESS. BUILT RIGHT THE FIRST TIME - SAVE ON LABOR & TIME.

OUR 3 TIER PACKAGE SYSTEMS ARE FUTURE BUILT WITH EVERY COMPONENT SELECTED TO DELIVER A SUPERIOR 4X4 VEHICLE EXPERIENCE ON & OFF ROAD



4RUNNER
3RD GEN TO 5TH GEN



TACOMA
1ST TO 3RD GEN

COMFORT LOAD 0-3" 4RUNNER 3RD - 5TH GEN

SMOOTH CONTROLLED BALANCED HANDLING ON & OFF ROAD WEEKEND TRAIL WARRIOR

- Assembled Struts
- Front & Rear Factory /Light Load Coils
- Twin Tube Struts & Rear Shocks
- Diff Drop Kit
- UCA (optional but required 2.5" and above for proper alignment & travel)
- 3" lifts use extended travel struts (additional 1" of travel)
- Coil Color Options -Teal- Red -Black
- Shims for drivers lean & kdss offset
- Shock Color Options – Black - Yellow

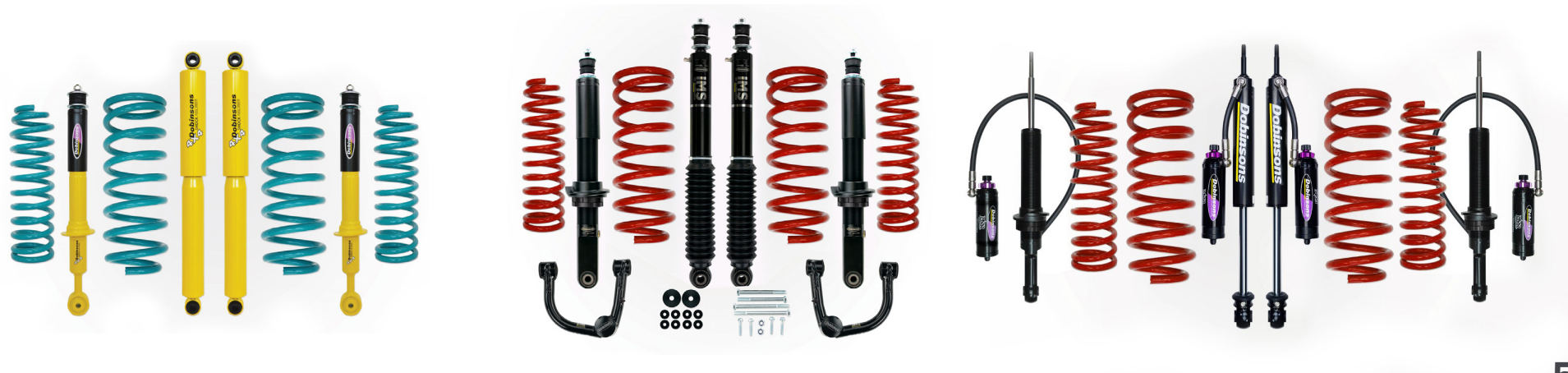

MEDIUM LOAD 4RUNNER 3RD - 5TH GEN

THE KIT FOR THOSE LIGHT ACCESSORIES & SEASONED TRAIL SEEKERS

- Assembled Struts
- Front & Rear Medium Duty Coils (up to 200lbs)
- Twin Tube Struts & Rear Shocks
- Diff Drop Kit
- UCA (optional but required 2.5" and above for proper alignment & travel)
- 3" lifts use extended travel struts
- Coil - Color Options: Teal, Red and Black
- Shock Options - Twin Tubes - IMS - MRR
- Shims for drivers lean & KDSS offset
- Shock - Color Options: Black and Yellow twin tubes only

Additional Options & Trail Worthy Upgrades

- Adjustable Panhard Rods
- Adjustable Upper & Lower Rear Trailing Arms
- Extended Sway Bar Links



HD-OVERLANDER - FLEXX WORTHY 4RUNNER 3RD -5TH GEN

THE HARDCORE ENTHUSIAST – TRAVELER & OVERLANDER

- Assembled Struts
- Front & Rear HD Coils (up to 1000lbs rear *)
- Constant Load or Variable Rate Coils for rear end
- Twin Tube Strus & Rear Shocks (LONG TRAVEL)
- Diff Drop Kit
- UCA
- 3" lifts use extended travel struts
- Front Sway Bar Extension Kit
- Coil Color Options -Teal- Red -Black
- Shock Options Twin Tubes-IMS -MRR
- Shock Color Options – (Black /Yellow-twin tubes only)
- Adjustable Panhard Rods
- Adjustable Upper & Lower Rear Trailing Arms
- Extended Sway Bar Links



COMFORT LOAD 0-3" TACOMA 1ST - 3RD GEN 3RD - 5TH GEN

SMOOTH CONTROLLED BALANCED HANDLING ON & OFF ROAD -WEEKEND TRAIL WARRIOR

- Assembled Struts
- Front Light Load Coils
- Twin Tube Strus & Rear Shocks
- Diff Drop Kit
- UCA (optional but required 2.5" and above for proper alignment & travel)
- 3" lifts use extended travel struts (additional 1'of travel)
- Coil Color Options -Teal- Red -Black
- Shock Options Twin Tubes-IMS -MRR
- Shim for drivers lean
- Quick Ride System – (U bolt & lift block) 1.25" & 2"
- Shock Color Options – Black - Yellow



MEDIUM LOAD TACOMA 1ST -3RD GEN

THE KIT FOR THOSE LIGHT ACCESSORIES & SEASONED TRAIL SEEKERS

- Assembled Struts
- Medium Load Coils
- Twin Tube Strus & Rear Shocks
- Diff Drop Kit
- UCA (optional but required 2.5" and above for proper alignment & travel)
- 3" lifts use extended travel struts (additional 1'of travel)
- Coil Color Options -Teal- Red -Black
- Shim for drivers lean
- Shock Options Twin Tubes-IMS -MRR
- Shock Color Options – Black - Yellow (twin tubes)
- Front Sway Bar Relocation Kit
- Greaseable Pins
- Polyurethane Leaf Spring Bushing Kit
- Medium Load Leaf Spring Pack (up to 220lbs constant load) 2.1"

Notes

- Tacoma Single Cab / Double Cab SB - 2.1" 600lb Constant Load
- Tacoma Double Cab LB - 2.1" 0-220lb Load

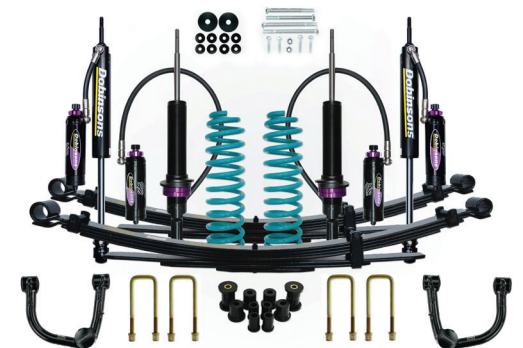
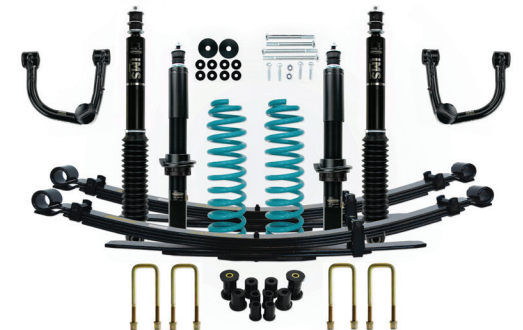

HD-OVERLANDER -FLEXX WORTHY TACOMA 1ST -3RD GEN

THE HARDCORE ENTHUSIAST – TRAVELER & OVERLANDER

- Assembled Struts
- Medium Load Coils
- Twin Tube Strus & Rear Shocks
- Diff Drop Kit
- UCA (optional but required 2.5" and above for proper alignment & travel)
- 3" lifts use extended travel struts (additional 1'of travel)
- Coil Color Options -Teal- Red -Black
- Shim for drivers lean
- Shock Options Twin Tubes-IMS -MRR
- Shock Color Options – Black - Yellow (twin tubes)
- Front Sway Bar Relocation Kit
- Greaseable Pins
- Polyurethane Leaf Spring Bushing Kit
- Heavy Load Leaf Spring Pack (up to 800lbs constant load) 2.1"
- Extra HD Load (up to 1200lbs constant load) 2.1"

Notes

- Tacoma Single Cab / Double Cab SB - 2.1" 880-1210lb Constant Load
- Tacoma Double Cab LB - 2.1" 600lb Constant Load

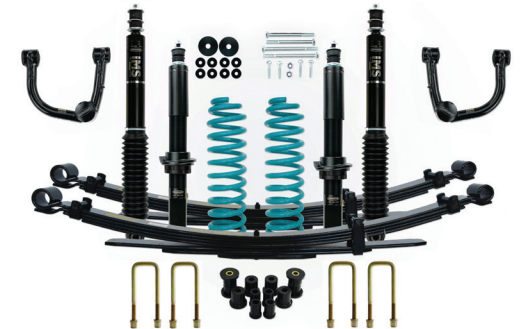



IMS SHOCKS

Dobinsons IMS monotube shock absorbers are designed for next level performance over twin tube shocks in those hot, harsh, demanding conditions. By utilising the monotube design, Dobinsons IMS shock absorbers are able to resist fade far longer on corrugated roads, long or hard working 4WD trips, towing or racing conditions.

Composite piston wear bands, high quality Fuchs oil and a race style 3-stage sealing system offer the lowest levels of friction whilst maintaining durability and longevity without the need for frequent rebuilding or servicing. Dobinsons team of engineers spend hundreds of hours of testing and tuning the shim stacks and damping characteristics in each IMS shock to ensure a balance of comfort, handling, vehicle control and off-road performance.



MRR SHOCKS

HIGH PERFORMANCE RACE-BRED MONOTUBE TECHNOLOGY

Built on the back of the race winning Monotube Remote Reservoir (MRR) shock absorbers, Dobinsons new range of MRR Adjustable shock absorbers combine the best in high performance race-bred Monotube technology, with an all new 3-way damping adjustment system to turn your 4x4 into the ultimate off-road machine.



COIL SPRINGS

Dobinsons Spring & Suspension™ proudly manufacture the highest quality replacement coil springs for many different applications to ISO9001:2008 international quality standards from their state of the art manufacturing facility in Central Queensland, Australia.

WORLDS LARGEST

RANGE OF COIL SPRINGS

Dobinsons™ proudly boast one of the worlds largest range of coil springs including raised height and heavy duty 4wd springs, lowered performance passenger car springs, O.E. replacement springs and heavy duty springs for commercial vehicles.

As Dobinsons™ coil springs are manufactured in-house, Dobinsons™ can manufacture smaller quantities and in most cases there are many different coil spring options available for your vehicle. This ensures the customer receives the best spring to suit their application and avoids a “One Size Fits All” scenario, especially important when selecting the correct spring rates and ride heights.

When matched with a set of corresponding Dobinsons™ Shock Absorbers, Dobinsons™ can provide you with unrivalled performance and handling.

THE LATEST TECHNOLOGY

Dobinsons new coil spring cold roller is the latest addition to the coil spring manufacturing process. Cold rolling coil springs dramatically decreases production time without compromising strength or durability, maintaining the high quality you expect from Dobinsons.

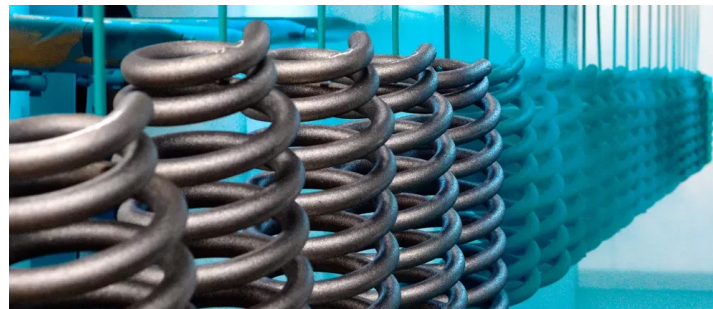
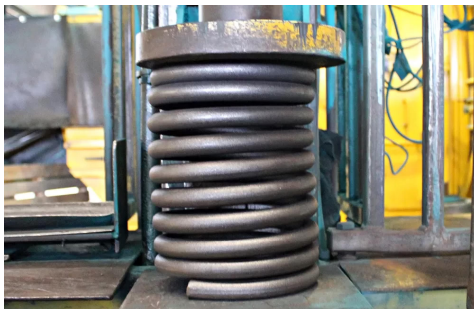

REAR DRAWERS

Dobinsons Rear Drawers come pre-assembled for easy fitment and include a heavy-duty fridge slide and 8 heavy duty tie down points to optimise the space on top.

All Drawers have a 150kg capacity and are constructed using 12mm Heavy Duty Plywood Panels with Marine Carpet Covering. With 3 sizes and Outer Wing Kits available, maximising your vehicles' storage space couldn't get any easier.



Rear Drawers - Steel Construction

ROLLER BEARINGS

Heavy Duty Roller Bearing System



Rear Drawers - Tie Down Points

TIE DOWN POINTS

8 x Heavy-Duty Stainless-Steel Tie Down Points



Rear Drawers - Wing Kits

OUTER WING KITS

Outer Wing Kits provide a factory fit (sold separately).

FEATURES

1.6mm Zinc Plated Robust Steel Construction | 12mm Heavy Duty Plywood Panels with Marine Carpet Covering
Single Side Inbuilt, Heavy Duty Fridge Slide | Aluminium Edging Protection | Supplied Pre-Assembled for Simple Fitment
Heavy Duty Lockable Latches | 150Kg Drawer Capacity | Heavy Duty Roller Bearing System
8 x Heavy-Duty Stainless-Steel Tie Down Points | Outer Wing Kits provide a factory fit (sold separately).

CONTROL ARMS

Dobinsons Heavy Duty Upper control arms are manufactured from 35, 36 and 38mm Chrome-Moly Tubing with an extra thick 5mm wall, for the ultimate in strength and reliability. When raising an IFS vehicle beyond 2" in the front suspension the wheel alignment geometry prevents a correct wheel alignment being performed.

Dobinsons Upper Control arms are designed with upto 3° increased castor and decreased camber to allow the wheel alignment to be corrected at larger lifts

NATURAL RUBBER BUSHINGS

OEM Quality Natural Rubber Bushings provide silent, maintenance free, long-life operation (feature shot of bushes)

QUALITY BALL JOINTS

555™ OEM quality Ball Joints used where available

INCREASED CLEARANCE

Improved design offers increased clearance to suspension components for improved suspension travel





SNORKELS

DRY ENGINE, CLEANER AIR INTAKE

Whether you are crossing the desert or a river, Dobinsons 4x4 Snorkels keep your engine protected from excess water intake and free of dust.

Dobinsons 4x4 Snorkel

Dobinsons 4x4 Snorkel Head

Installing a snorkel to your 4x4 is considered one of the most essential modifications made to your vehicle before heading out on extended trips, or before taking your 4x4 through deep water crossings.

The original air intake position on most 4x4 vehicles is under the bonnet or inside the wheel arch, areas prone to high heat and water and dust ingress. Dobinsons 4x4 Snorkels provide piece of mind and a healthy engine after those off-road adventures.

LIGHTS

ZENITH 155 WATT LED DRIVING LIGHT

The Zenith 155 watt LED Driving light combines two years of research, testing and development to offer the ultimate in LED driving light performance. Combining 4 x 20 watt extra deep-dish long-distance LED chips and 15 x 5 watt spread LED chips, the Zenith driving light has been designed, tested and proven in Australia to provide a combination of long distance and close-spread clear white light. The 8.25" multi-fin alloy housing combined with a heavy-duty steel mounting bracket and polycarbonate lens ensures the Zenith Driving light will continue to perform in the harshest terrain.



FEATURES

IP68 Water & Dust Proof Rating | Multi-Fin Heat Dispersing Alloy Housing | 50,000 Hour Life Span | Waterproof Connecting Plugs
10-30V DC Multi-Voltage Compatible | Super Tough Polycarbonate Covers | 6500K Cree LED Modules
10° Spot-Beam Long Distance Reflectors | Heavy Duty Adjustable Mounting Base

ORS GUARANTEE

HELPING YOU FIND NEW ROADS

YOUR PROJECT & BUILD ARE OUR MISSION , TO DELIVER QUALITY, CONSISTENT SERVICE TO OUR CLIENTS USING INDUSTRY LEADING PROVEN BRANDS IN AN EFFICIENT MANNER.



**WE DELIVER ON TIME,
BECAUSE WE RESPECT
YOUR TIME.**



**WE EMPLOY HIGHLY
TRAINED STAFF THAT
ARE READY TO HELP.**



**WE WILL ALWAYS
MARKET OUR PRODUCTS
AND PRICING HONESTLY.**



**WE BUILD VEHICLE WITH
THE HIGHEST GRADE
PRODUCTS POSSIBLE.**





WINNIPEG, MANITOBA